

Technical sheet :

# **AETJ 49**

---



Capacities		Imperial
Working height	h21	55 ft 5 in
Platform height	h7	48 ft 11 in
Max. outreach	r1	30 ft 11 in
Overhang	h31	23 ft
Pendular arm rotation (top / bottom)		+65 ° / -65 °
Platform capacity	Q	500 lbs
Turret rotation		355 °
Platform rotation (right / left)		66 ° / 59 °
Number of people (inside / outside)		2 / 2
Weight and dimensions		
Platform weight*		15642 lbs
Platform dimensions (length x width)	lp / ep	3 ft 11 in x 3 ft
Overall width	b1	5 ft 9 in
Overall length	l1	22 ft 5 in
Overall height	h17	6 ft 6 in
Overall length (stowed)	l9	16 ft 10 in
Overall height (stowed)	h18	6 ft 8 in
Floor height (access)	h20	1 ft 4 in
Jib length	l13	4 ft 2 in
Counterweight offset (turret at 90°)	a7	3 in
Internal turning radius (over tyres)	b13	6 ft 7 in
External turning radius	Wa3	14 ft 1 in
Tailswing		3 in
Ground clearance at centre of wheelbase	m2	6 in
Wheelbase	y	6 ft 7 in
Performances		
Drive speed - stowed		3.1 mph
Drive speed - raised		0.4 mph
Gradeability		22 %
Permissible leveling		3 °
Wheels		
Tyres type		Solid non-marking tires
Dimensions of front wheels / rear wheels		0,60x0,19m - 0,60x0,19m
Drive wheels (front / rear)		0 / 2
Steering wheels (front / rear)		2 / 0
Braking wheels (front / rear)		0 / 2
Engine/Battery		
Electric engine power rating		2 x 4.5 kW
Electric Pump		3.7 kW
Battery / Batteries capacity		48 V / 240 Ah
Integrated charger (V / Ah)		48 V / 30 mAh
Miscellaneous		
Number of cycles with STD Battery (HIRD)		44
Ground Pressure		240.76 PSI
Hydraulic Pressure		14 PSI
Hydraulic tank capacity		3.96 US gal
Vibration on hands/arms		< 8.2 ft/s
Standards compliance		
This machine is in compliance with:		ANSI A92.20-2018 CSA B354.6 ICES-002-Issue 6 Standard Canadian EMC

# Load chart

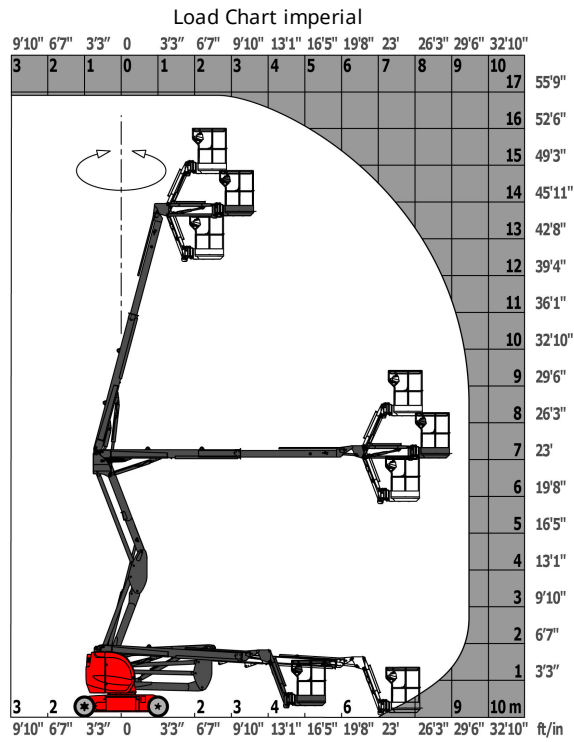

## Dimensional drawing

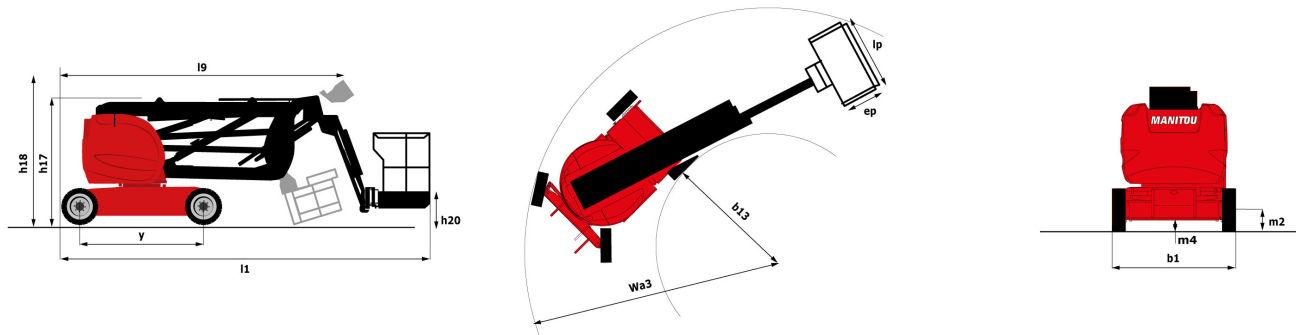

## Equipment

### Standard

- 110 V plug with differential circuit breaker
- Audible alarm and illuminated indicator lamp (leveling, overload, lowering)
- Battery charge indicator lamp
- CAN bus technology
- Drive safety orientation system
- Electric predisposition on boom
- Emergency stop button in platform and on frame
- Horn in the platform
- Hour meter
- Integrated diagnostic assistance
- Manual emergency lowering
- Multi-voltage integrated charger
- Negative-type braking on rear wheels
- Non-marking rubber tyres
- Platform access gate
- Proportional controls
- Slings and securing rings
- Tool box in platform
- Traction battery
- Travel possible at maximum height

### Optional

- Air predisposition
- Beep on every movement
- Beep upon travel
- Biodegradable oil
- Cold weather kit
- Extreme cold oil
- Flashing Light
- Highly capacity battery
- Protective cover for control panel
- SMS : Safe Man System
- Water predisposition
- Working headlight in platform



Siège Social  
430 rue de l'Aubinière - 44150 Ancenis Cedex - France  
Tel: +33(0)2 40 09 10 11 - Fax: +33 (0)2 40 09 10 97  
[www.manitou.com](http://www.manitou.com)



This brochure describes versions and configuration options for Manitou products which may be fitted with different equipment. The equipment described in this brochure may be standard, optional or not available depending on version. Manitou reserves the right to change the specifications shown and described at any time and without prior warning. The manufacturer is not liable for the specifications given. For more information, contact your Manitou dealer. Non-contractual document. Product descriptions may differ from actual products. List of specifications is not comprehensive. The logos and visual identity of the company are the property of Manitou and may not be used without authorisation. All rights reserved. The photos and diagrams contained in this brochure are provided for information only.

MANITOU BF SA - Limited company with board of directors - Share capital: 39,668,399 euros - 857 802 508  
RCS Nantes