

Technical sheet :

M 40-2



Technical characteristics			Metric	Imperial
1.1	Manufacturer		Manitou	Manitou
1.2	Model Name		M 40-2	M 40-2
1.3	Power source		Diesel	Diesel
1.4	Operator type		Seated	Seated
1.5	Max. capacity	Q	4000 kg	8818 lbs
1.6	Load centre of gravity	c	500 mm	19.685 in
1.8	Load distance, centre of drive axle to fork	x	763 mm	30.039 in
1.9	Wheelbase	y	2060 mm	81.102 in
Weight				
2.1	Service Weight		6915 kg	15245 lbs
2.2	Weight on front axle (laden) / rear axle (laden)		9075 kg / 1840 kg	20007 lbs / 4057 lbs
2.3	Weight on front axle (Unladen) / rear axle (Unladen)		2625 kg / 4290 kg	5787 lbs / 9458 lbs
Wheels				
3.1	Tyres type		Pneumatic	Pneumatic
3.2	Dimensions of front wheels		18x19.5 18PR A224	18x19.5 18PR A224
3.3	Dimensions of rear wheels		10R17.5 G291 GY	10R17.5 G291 GY
3.5	Number of front wheels / rear wheels		2 / 2	2 / 2
3.2	Number of drive wheels		2	2
3.6	Front wheel gauge	b10	1600 mm	62.992 in
3.7	Rear wheel gauge	b11	1640 mm	64.567 in
Dimensions				
4.1	Tilt of Mast Forward (deg) / Backward (deg)	α / β	15 / 15	15 / 15
4.7	Height of overhead guard (cabin)	h6	2460 mm	96.85 in
4.7	Overall height of standard overhead guard	h6	2460 mm	96.85 in
4.8	Seat height/stand height	h7	1440 mm	56.693 in
4.12	Height of towing bar (coupling height)	h10	690 mm	27.165 in
4.19	Overall length	l1	4858 mm	191.26 in
4.20	Length to face of forks	l2	3658 mm	144.016 in
4.21	Overall width	b1	2057 mm	80.984 in
4.22	Forks section / width / length	s / e / l	50 mm x 150 mm / 1200 mm	1.969 in x 5.906 in / 47.244 in
4.23	Fork carriage ISO 2328 (class/form) A/B		FEM3	FEM3
4.24	Fork carriage width	b3	1670 mm	65.748 in
4.31	Ground clearance below mast	m1	250 mm	9.843 in
4.32	Ground clearance at centre of wheelbase	m2	310 mm	12.205 in
4.33	Aisle width for 1000 x 1200 pallet widthways	Ast	5560 mm	218.898 in
4.34	Aisle width for 800 x 1200 pallet lengthways	Ast	5560 mm	218.898 in
4.35	Turning radius	Wa	3395 mm	133.661 in
4.36	Internal turning radius (over tyres)	b13	200 mm	7.874 in
Performances				
5.1	Travel speed (laden / unladen)		10 km/h / 24 km/h	6.2 mph / 14.9 mph
5.2	Lifting speed (laden / unladen)		0.4 m/s / 0.4 m/s	1.31 ft/s / 1.31 ft/s
5.3	Lowering speed (laden / unladen)		0.4 m/s / 0.3 m/s	1.31 ft/s / 0.98 ft/s
5.5	Drawbar pull (Laden)		6900 daN	6900 daN
5.9	Service brake		Hydraulic	Hydraulic

Engine				
7.1	Engine brand / model / norm		Perkins / 854F-E34T WF / Stage 3B	Perkins / 854F-E34T WF / Stage 3B
7.2	Engine power according to ISO 1585		55 kW	55 kW
7.3	Rated speed		2200 tr/min	2200 tr/min
7.4	Number of cylinders / Capacity of cylinders		4 - 3400 cm ³	4 - 207.48 in ³
	Fuel consumption according to VDI cycle		6.9 l/h	6.9 l/h
Miscellaneous				
8.2	Working hydraulic pressure for attachments		210 Bar	14 PSI
8.3	Oil flow rate for attachments		97 l/min	97 l/min
8.4	Measured/guaranteed mean noise level at the ear of the operator		< 76 dB(A)	< 76 dB(A)

Dimensional drawing

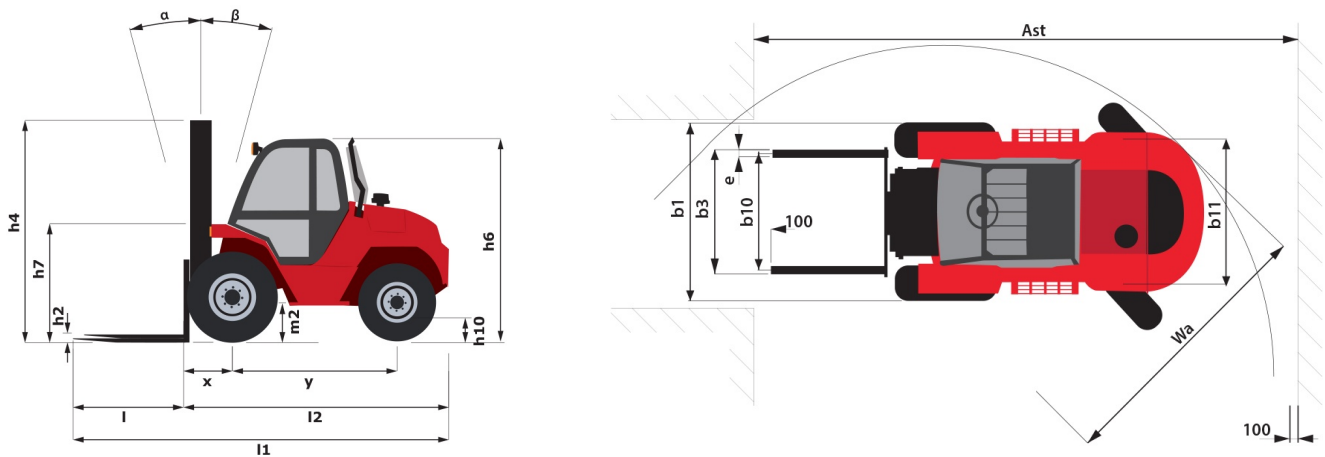

Characteristics of masts and residual capacities

Full Visibility Duplex		FVD 30	FVD 33	FVD 35	FVD 37	FVD 40	FVD 45	FVD 50
h2 - Free lift	mm	0	0	0	0	0	0	0
h1 - Height mast lowered *	mm	2425	2575	2675	2775	2925	3175	3425
h3 - Lifting Height	mm	3000	3300	3500	3700	4000	4500	5000
h4 - Height mast extended *	mm	3977	4277	4477	4677	4977	5477	5977
α / β - Mast inclination (front / rear)	°	15 / 15	15 / 15	15 / 15	15 / 15	15 / 15	15 / 15	15 / 15
Residual capacity at max height	kg	4000	4000	4000	4000	4000	4000	3800
Residual capacity without attachment (Industrial load chart)	kg	4000	4000	4000	4000	4000	4000	3800
Residual capacity with integrated side shift (Industrial load chart)	kg	4000	4000	4000	4000	4000	4000	3400

Free Lift Triplex		FLT 37	FLT 40	FLT 43	FLT 45	FLT 47	FLT 50	FLT 55	FLT 60
h2 - Free lift	mm	1258	1258	1458	1533	1593	1708	1858	2033
h1 - Height mast lowered *	mm	2175	2275	2375	2450	2510	2625	2775	2950
h3 - Lifting Height	mm	3700	4000	4300	4500	4700	5000	5500	6000
h4 - Height mast extended *	mm	4667	4967	5267	5467	5667	5967	6767	6967
α / β - Mast inclination (front / rear)	°	15 / 15	15 / 15	15 / 15	15 / 15	15 / 15	15 / 15	15 / 15	15 / 15
Residual capacity at max height	kg	4000	4000	4000	4000	3800	3700	3200	2600
Residual capacity without attachment (Industrial load chart)	kg	4000	4000	4000	4000	3800	3700	3200	2600
Residual capacity with integrated side shift (Industrial load chart)	kg	4000	4000	4000	4000	3400	3300	2900	2350

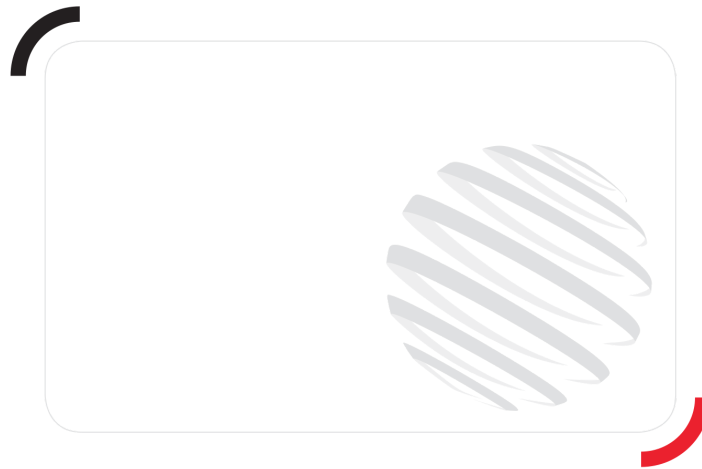

Siège Social

430 rue de l'Aubinière - 44150 Ancenis Cedex - France

Tel: +33(0)2 40 09 10 11 - Fax: +33 (0)2 40 09 10 97

www.manitou.com



This brochure describes versions and configuration options for Manitou products which may be fitted with different equipment. The equipment described in this brochure may be standard, optional or not available depending on version. Manitou reserves the right to change the specifications shown and described at any time and without prior warning. The manufacturer is not liable for the specifications given. For more information, contact your Manitou dealer. Non-contractual document. Product descriptions may differ from actual products. List of specifications is not comprehensive. The logos and visual identity of the company are the property of Manitou and may not be used without authorisation. All rights reserved. The photos and diagrams contained in this brochure are provided for information only.

MANITOU BF SA - Limited company with board of directors - Share capital: 39,668,399 euros - 857 802 508
RCS Nantes